



CMSI-1616

16 by 16 Modular Matrix



Operation Manual



HDMI[®]
HIGH-DEFINITION MULTIMEDIA INTERFACE

The terms HDMI, HDMI High-Definition Multimedia Interface, and the HDMI Logo are trademarks or registered trademarks of HDMI Licensing Administrator, Inc.

DISCLAIMERS

The information in this manual has been carefully checked and is believed to be accurate. Cypress Technology assumes no responsibility for any infringements of patents or other rights of third parties which may result from its use.

Cypress Technology assumes no responsibility for any inaccuracies that may be contained in this document. Cypress also makes no commitment to update or to keep current the information contained in this document.

Cypress Technology reserves the right to make improvements to this document and/or product at any time and without notice.

COPYRIGHT NOTICE

No part of this document may be reproduced, transmitted, transcribed, stored in a retrieval system, or any of its part translated into any language or computer file, in any form or by any means—electronic, mechanical, magnetic, optical, chemical, manual, or otherwise—without express written permission and consent from Cypress Technology.

© Copyright 2018 by Cypress Technology.

All Rights Reserved.

TRADEMARK ACKNOWLEDGMENTS

All products or service names mentioned in this document are trademarks of the companies with which they are associated.



SAFETY PRECAUTIONS

Please read all instructions before attempting to unpack, install or operate this equipment and before connecting the power supply. Please keep the following in mind as you unpack and install this equipment:

- Always follow basic safety precautions to reduce the risk of fire, electrical shock and injury to persons.
- To prevent fire or shock hazard, do not expose the unit to rain, moisture or install this product near water.
- Never spill liquid of any kind on or into this product.
- Never push an object of any kind into this product through any openings or empty slots in the unit, as you may damage parts inside the unit.
- Do not attach the power supply cabling to building surfaces.
- Use only the supplied power supply unit (PSU). Do not use the PSU if it is damaged.
- Do not allow anything to rest on the power cabling or allow any weight to be placed upon it or any person walk on it.
- To protect the unit from overheating, do not block any vents or openings in the unit housing that provide ventilation and allow for sufficient space for air to circulate around the unit.
- Please completely disconnect the power when the unit is not in use to avoid wasting electricity.

VERSION HISTORY

REV.	DATE	SUMMARY OF CHANGE
RDV1	2013/07/05	Preliminary Release
RDV2	2013/10/31	Panel's Printing
RDV3	2014/04/21	Package Contents Add IR Cables
RDV4	2014/06/30	RS-232 Command & CIN-8DS model
RDV5	2015/01/21	UART Command
RDV6	2015/03/05	Add IR Command
RDV7	2015/04/23	Add IR Pin Assignment
VS0	2015/04/27	Updated Text/Diagrams
RDV8	2015/11/06	5Play Output Module Add LAN
VS1	15/08/16	Updated IRMASK command descriptions

CONTENTS

1. Introduction	1
2. Applications	1
3. Package Contents	1
4. System Requirements	2
5. Features	2
6. Operation Controls and Functions	3
6.1 Front Panel.....	3
6.2 Rear Panel.....	5
6.3 Remote Control	6
6.4 IR Cable Pin Assignments.....	7
6.5 RS-232 Protocols	7
6.6 RS-232 and Telnet Commands	8
6.7 Telnet Control	12
6.8 WebGUI Control	14
7. Connection Diagram	15
7.1 Example Installation (16×16 HDMI Matrix).....	15
7.2 Input and Output Modules	16
8. Specifications	17
8.1 Technical Specifications (Enclosure).....	17
8.2 Technical Specifications (Input Modules)	18
8.3 Technical Specifications (Output Modules).....	19
8.4 CAT5e/6/7 Cable Specifications	22
9. Acronyms	23



1. INTRODUCTION

The 16 by 16 Modular Matrix is designed to allow the switching and distribution of up to 16 source devices to up to 16 connected displays, either directly via HDMI, DVI or via CAT5e/6/7 outputs to compatible receivers, providing control options (dependent on module configuration).

Providing unparalleled levels of flexibility, with an advanced modular design these models can be setup in a wide variety of combinations allowing users the ability to tailor the Matrix to their requirements by simply adding or removing the input or output modules as required.

The Modular Matrix is supplied with dual removable internal PSU's which allow for easy inspection and maintenance with zero down time. Also included is a DVI output for local monitoring of the output allowing installers to easily monitor, test, and configure the Inputs and Outputs on installation.

In addition, this matrix also features IP control allowing users to access and control the matrix remotely and also allow additional options for integration of third-party control systems.

2. APPLICATIONS

- Public information display
- Educational demo
- Professional presentation
- Advertising display

3. PACKAGE CONTENTS

- 1×16 by 16 Modular Matrix Enclosure (including CPU Control Board and Removeable Dual Power Supplies)
- 2×Input Module Boards - HDMI, DVI, CAT5e/6/7 or VGA (Optional)
- 2×Output Module Boards - HDMI, DVI or CAT5e/6/7 (Optional)
- 1×IR Extender
- 1×IR Blaster
- 1×Remote Control (with Battery)
- 2×Power Cords
- 1×Operation Manual

4. SYSTEM REQUIREMENTS

- Up to 16 HDMI, DVI, CAT5e/6/7 or VGA source devices (dependent on module configuration) connected with appropriate cables.
- Up to 16 displays (TV or monitor) or AV receivers, equipped with HDMI, DVI, CAT5e/6/7 connection (dependent on module configuration) connected with appropriate cables
- Industry standard CAT5e/6/7 cable (for CAT5e/6/7 inputs/outputs)
- Compatible PoC HDBaseT™ Transmitters/Receivers for CAT5e/6/7 Input/Output modules

5. FEATURES

- HDMI, HDCP 1.4 and DVI 1.0 compliant
- Interchangeable input and output modules
- Input and output module types can be mixed and added in multiples of 8 from 8×8 (1 Input module, 1 Output module) up to 16×16 (2 Input modules, 2 Output modules) with HDMI, DVI, CAT5e/6/7 and VGA (Input only) connection types
- Supports a wide range of PC and HDTV resolutions from VGA to WUXGA and 480i to 1080p and 4K2K@24/25/30
- Supports pass-through of LPCM 7.1CH, Dolby TrueHD, Dolby Digital Plus and DTS-HD Master Audio
- Supports control of the matrix via on-panel, RS-232, Telnet and WebGUI controls
- Supports 10 available preset settings
- Support 3 EDID modes: Standard, Dynamic and Manual (see Section 6.1 for details)
- Dual removal power supply units
- Supports HDMI cable input and output lengths of up to 15m each way (1080p@8-bit resolution), 10m (1080p@12-bit resolution) or 5m (4K2K@30 resolution)
- Supports CAT5e/6/7 cable input and output lengths of up to 100m (1080p@8-bit/12-bit resolution) or 70m (4K2K@30 resolution) dependent on board capabilities
- HDBaseT 5Play™ convergence supports HD Video, HD Audio, PoC, Ethernet and IR/RS-232 Control
- HDBaseT 4Play convergence supports HD Video, HD Audio, PoC and IR/RS-232 Control
- HDBaseT 3Play convergence supports HD Video, HD Audio and IR/RS-232 Control

6. OPERATION CONTROLS AND FUNCTIONS

6.1 Front Panel

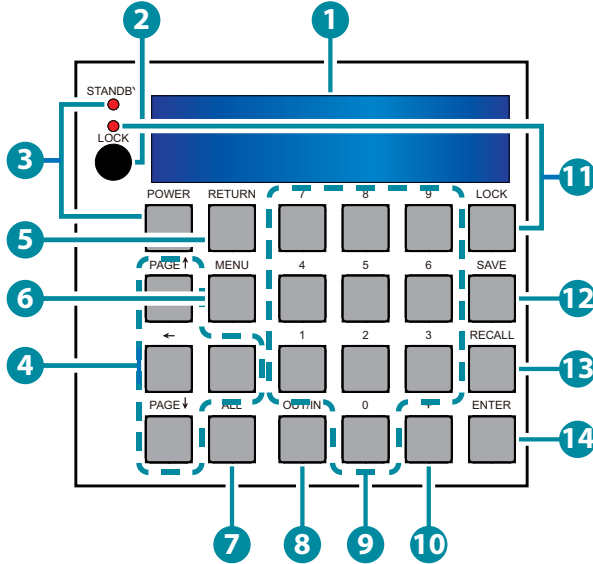

- 1 **LCM:** Displays the setting information of each input/output and other setting information according to the selected mode.
- 2 **IR WINDOW:** Accepts the IR remote control signal for the matrix only.
- 3 **POWER:** Press this button to turn the matrix on or press it again to put the matrix into standby mode. The LED will illuminate when the unit is in standby mode.

Note: If the LED is flashing it means the temperature inside is too high and air circulation may have been restricted.

- 4 **PAGE (▲/▼/◀/▶):** Use these buttons to cycle through the LCM's pages for displaying the current I/O status or when entering into the settings menu.
- 5 **RETURN:** Press this button to return back or exit the current selection.
- 6 **MENU:** Press this button to enter the menu to change the following settings:
 - **EDID:** Support 3 EDID modes.
 1. *Standard Mode:* Uses the built-in EDID settings that support video

up to 1080p@60 or WUXGA@60 (RB) video and LPCM 2CH audio.

2. *Dynamic Mode*: Reads the EDID settings from the display connected to the lowest numbered output port.
 3. *Manual Mode*: Supports independent EDID settings by selecting the input and output ports.
- **IP**: Displays the setting information of IP address, IP Netmask and IP Gateway.
 - **Temperature**: These figures show the internal temperature of the matrix.
 - **LCM**: Supports LCM contrast range from 1 to 4.

- 7 **ALL**: Press this button to assign the same input to all outputs.
- 8 **OUT/IN**: Press to assign the source to be displayed on the required output. The sequence should be OUT/IN→Select the Input→OUT/IN→a Select the output→Enter.
- 9 **NUMBERS (0~9)**: Use to select the appropriate numbered input or output.
- 10 **PLUS (+)**: Press this button when multiple outputs are required for a selected input. This button only works in conjunction with the OUT/IN button.
- 11 **LOCK**: Press this button to lock all the function buttons on panel. The LED will illuminate, to unlock press it again.
- 12 **SAVE**: Press this button to store the present Input/Output configuration to one of the 10 available preset settings.
- 13 **RECALL**: Press this button to recall a previously stored preset setting.
- 14 **ENTER**: Press this button to confirm a setting or selection in the menu.

6.2 Rear Panel

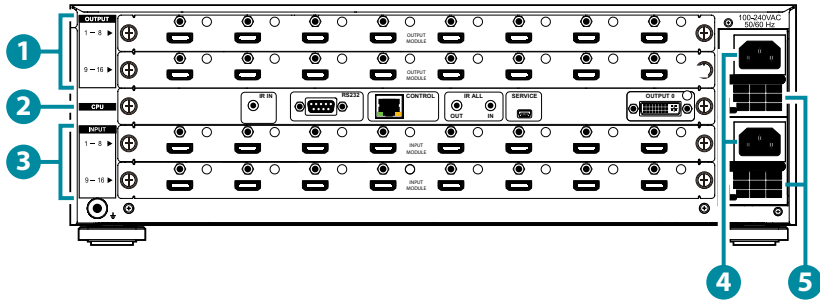

Note: The above panel is an example of 16×16 HDMI configuration.

- 1 **OUTPUTS 1~16:** Install up to 2 Output modules as required for up to 16 displays (TV or monitor) or CAT5e/6/7 outputs for compatible HDBaseT receivers (dependent on module configuration).

- 2 **CPU (Control Board)**

IR IN: For IR control of the matrix only. Connect to the IR Extender for IR signal reception of the IR remote control of the matrix. Ensure that the remote being used is within the direct line-of-sight of the IR Extender.

RS-232: Connect to a PC/Laptop with a D-sub 9-pin cable for RS-232 command sending and controlling over the Matrix.

CONTROL: Connect to an active network for LAN serving and Telnet/ WebGUI control. LAN serving on compatible HDBaseT input/output modules and transmitters/receivers only.

ALL IR OUT: Connect the IR output to the IR Blaster for IR signal transmission of the equipment to be controlled. Place the IR Blaster in direct line-of-sight of the equipment to be controlled.

ALL IR IN: Connect the IR input to the IR Extender for IR signal reception of the IR remote control of the equipment to be controlled. Ensure that remote being used is within the direct line-of-sight of the IR Extender.

Note: For IR control of the HDBaseT input/output modules and transmitters/receivers only. IR signals received by all IR Extenders connected to the transmitters/receivers will be transmitted by all IR Blasters connected to the transmitters/receivers.

SERVICE: Firmware update only.

OUTPUT 0: Connect to DVI equipped display or to an HDMI equipped

display (with DVI to HDMI adaptor) for local monitoring of the output signal.

- 3 **INPUT 1~16:** Install up to 2 Input modules as required for up to 16 source devices or CAT5e/6/7 inputs for compatible HDBaseT transmitters (dependent on module configuration).
- 4 **POWER SUPPLY:** The matrix will automatically turn on when connected to an active power supply.
- 5 **VENTILATION FAN:** This fan will automatically operate when the matrix is switched on. Do not block the exhaust of the fan or cover it with any object. Please allow adequate space around the unit for air to circulate freely.

6.3 Remote Control

- 1 **OUTPUT:** Output port selection
- 2 **INPUT:** Input port selection.
- 3 **ENTER:** Press to confirm the present input/output selection.
- 4 **CLEAR:** Press to clear the present input/output selection.

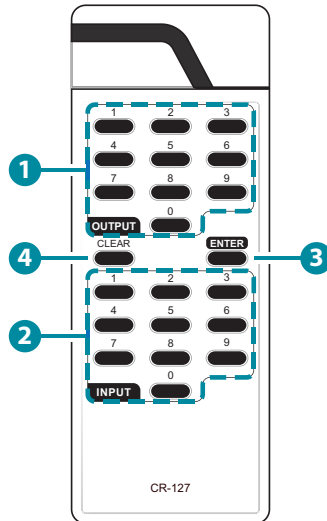

6.4 IR Cable Pin Assignments

IR Blaster Cable

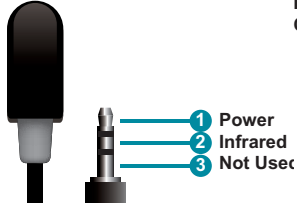

IR Extender Cable

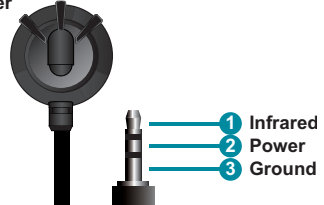

6.5 RS-232 Protocols

MATRIX	
Pin	Definition
1	NC
2	TxD
3	RxD
4	NC
5	GND
6	NC
7	NC
8	NC
9	NC



RS-232 CONTROLLER	
Pin	Definition
1	NC
2	RxD
3	TxD
4	NC
5	GND
6	NC
7	NC
8	NC
9	NC

Baud Rate: 19200bps

Data Bit: 8 bits

Parity: None

Stop Bit: 1

Flow Control: None

6.6 RS-232 and Telnet Commands

COMMAND	DESCRIPTION
P1	Power on
P0	Power off
Oxly	Set output (x=1~16) to input (y=1~16)
ALLOUT x	Set all outputs to input (x=1~16)
ACTIVE	Report active I/O channels
INDETECT	Input channels detection indicator
OUTDETECT	Output channels detection indicator
PORTSTATUS	Report all output connection status
HDCPON x	Set input port (x=1~16) HDCP to 'on'
HDCPOFF x	Set input port (x=1~16) HDCP to 'off'
HDCPONALL	Set all input port's HDCP to 'on'
HDCPOFFALL	Set all Input port's HDCP to 'off'
HDCPSTATUS	Show the HDCP status of all outputs (0=disabled, 1=enable)
MUTEO x	Mute video for output (x=1~16)
UNMUTEO x	Unmute video for output (x=1~16)
MUTEI x	Mute video for input (x=1~16)
UNMUTEI x	Unmute video for input (x=1~16)
MUTEALL	Mute all outputs
UNMUTEALL	Unmute all outputs
MUTESTATUS	Show the mute status of all outputs (0=unmuted, 1=muted)
HPDL x	Pull the input (x=1~16) hot-plug-detect signal to 'low'.
HPDH x	Pull the input (x=1~16) hot-plug-detect signal to 'high'

COMMAND	DESCRIPTION
HPDLALL	Set the hot-plug-detect of all inputs to 'low'
HPDHALL	Set the hot-plug-detect of all inputs to 'high'
HPDSTATUS	Report the hot-plug-detect signal status of all inputs
EDIDMODE x y	Set the EDID mode of input (x=1~16) to y (1~3)
EDIDMODEALL x	Set the EDID mode of all input to x (1~3)
EDIDPORT x y	Set the EDID mode of assigned port (y=1~16) to input (x=1~16)
EDIDPORTALL x	The EDID mode of all ports is assigned to output (x=1~16)
EDIDSTATUS	Report the status of the EDID modes of all inputs
IRMASKOUT x y z*	<p>Disable/enable (z=0/1) IR transmission from the IR input on the specified HDBaseT Output Module's port (y=1~16/all) to the currently routed HDBaseT Transmitter (x=src) or Receiver (x=sink)</p> <p>Example 1: "IRMASKOUT src 7 0" disables IR transmissions from the HDBaseT Output Module's IR In port #7 to the currently routed HDBaseT Transmitter's IR Out.</p> <p>Example 2: "IRMASKOUT sink 5 1" enables IR transmissions from the HDBaseT Output Module's IR In port #5 to the currently routed HDBaseT Receiver's IR Out.</p>

COMMAND	DESCRIPTION
IRMASKCPU x y z*	<p>Disable/enable (z=0/1) IR transmission from the IR ALL input on the CPU Control Board to the HDBaseT Transmitter (x=src), Receiver (x=sink) or Output Module (x=out) on to the specified port (y=1~16/all)</p> <p>Example 1: "IRMASKCPU src all 0" disables IR transmissions from the CPU Control Board's IR ALL In port to all connected HDBaseT Transmitters' IR Out.</p> <p>Example 2: "IRMASKCPU out 5 1" enables IR transmissions from the CPU Control Board's IR ALL In port to the HDBaseT Output Module's port #5 IR Out.</p>
SHOWIRMASKOUT x y*	Display the current IR mask setting for the specified HDBaseT Output Module's port (y=1~16/all) to HDBaseT Transmitters (x=src) or Receivers (x=sink)
SHOWIRMASKCPU x y*	Display the current IR mask setting for the IR ALL input on the CPU Control Board to the HDBaseT Transmitter (x=src), Receiver (x=sink) or Output Module (x=out) on to the specified port (y=1~16/all)
UART x y "str"	Write UART string to output port (x=in/out, y=1~16, "str"="string")
UARTBAUD x y	Set the UART Baud rate of output (x=1~16, y=rate)
STATUSUART	Show the UART Baud rate of output
TEMPSTATUS	Show temperature sensor values y1 and y2
SETIPADDR	Set the IP address (x.x.x.x)
SETSNMASK	Set the Subnet Mask address (x.x.x.x)

COMMAND	DESCRIPTION
SETGWADDR	Set the Gateway address (x.x.x.x)
IPCONFIG	Show the current IP configuration
RSTIP	Reset the IP configuration to default values (DHCP)
BUZZER x	Set the buzzer (0=mute, 1=unmute)
REBOOT	Reboot the system
SAVETO x	Save as preset x (1~10)
RECALLTO x	Recall the preset x (1~10)
RESET	Reset the system to O111, O212, O313, O414, O515, etc.
VERSION	Show the firmware version

Note:

1. *HELP: Show command list.*
2. *Commands will be not executed unless followed by a carriage return. Commands are not case-sensitive.*
3. *Commands marked with an asterisk (*) will only function with compatible HDBaseT Transmitters, Receivers and HDBaseT Output Modules.*

6.7 Telnet Control

Before attempting to use the Telnet control, please ensure that both the Matrix (via the 'LAN /CONTROL' port) and the PC/Laptop are connected to the same active networks.

To access the Telnet control in Windows 7, click on the 'Start' menu and type "cmd" in the Search field then press enter.

Under Windows XP go to the 'Start' menu and click on "Run", type "cmd" with then press enter.

Under Mac OS X, go to Go→Applications→Utilities→Terminal

See below for reference.

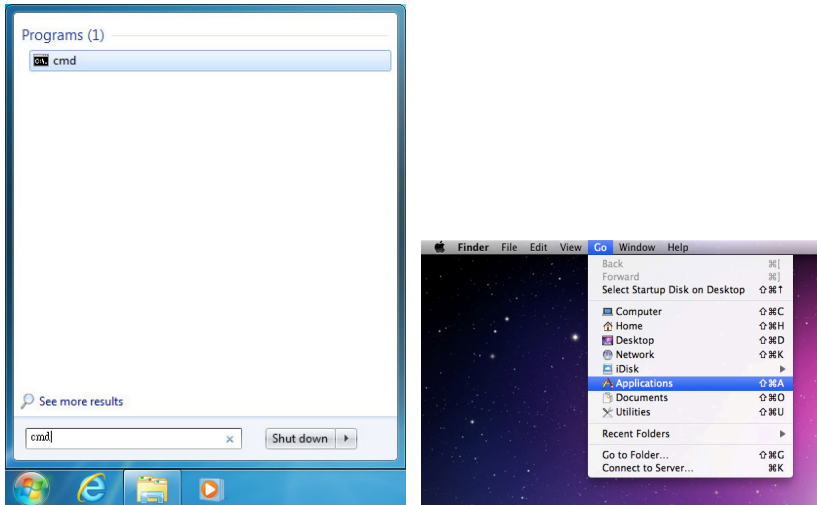

Once in the command line interface (CLI) type "telnet", then the IP address of the unit and "23", then hit enter.

```
Microsoft Windows [Version 6.1.7601]
Copyright (c) 2009 Microsoft Corporation. All rights reserved.

C:\Users\Administrator>telnet 192.168.5.80 23
```

Note: The IP address of the Matrix can be displayed on the unit's LCM monitor by pressing the MENU button twice.

This will bring us into the unit which we wish to control. Type "help" to list the available commands.

```
telnet-> help

          P0 : Power Off
          P1 : Power On
          RESET : System Reset to 01i1,02I2,03I3,04I4,05I5....
          0xxIxx(x:01~8) : Output 0~8 set to Input 1~8
          ALLOUT xx(x:01~8) : All Output set to Input 1~8
          MUTE xx(x:0~8) : Video mute command at output interface
          UNMUTE xx(x:0~8) : Video unmute command at output interface
          MUTEALL : Mute all outputs
          UNMUTEALL : Unmute all outputs
          SHOWMUTE : Show mute status of all output(0=not muted,1=muted)
          RDMUTE xx(x:0~8) : Read MUTE Status at Output
          HPDLow xx(x:01~8) : Pull the Hot-Plug-Detect signal to 'LOW'
          HPDHigh xx(x:01~8) : Pull the Hot-Plug-Detect signal to 'HIGH'
          HPDLow ALL : Set All Input HPD to Low
          HPDHigh ALL : Set All Input HPD to High
          SHOWHPD : Report ALL Input Hot-Plug-Detect signal status
          STATUSHPD x(x:1~8) : Show HPD status of input(x)
          SHOWTEMP : Show temperature sensor values y1, y2
          STATUSIN xx(x:01~8) : Report Input connection status
          STATUSOUT xx(x:0~8) : Report Output connection status
          STATUSALL : Report ALL Output connection status
          STATUSEDID : Report ALL Input EDID mode&port
          SETEDIDMODE ii mm(ii:01~8 mm:1~3) : Set EDID mode(mm) to Input(ii)
          SETEDIDMODE ALL mm (mm=1~3) : The EDID mode(mm) of All Input(ii)
          SETEDIDPORT ii pp(ii:01~8 pp:01~8) : Set EDID Assigned Port(pp) to Input(ii)
          SETEDIDPORT ALL mm (pp=01-8) : The EDID of All Inports is assigned to Output
          pp
          ACTIVE : Report I/O active channels
          INDETECT : Input channels detect indicator
          OUTDETECT : Output channels detect indicator
          IPCONFIG : Display the current IP config
          SETIP <IP> <SubNet> <GW> : Setting IP.ShuNet.GateWay(Static IP)
          RSTIP : IP Configuration Was Reset To Factory Defaults(DHCP)
          SETIPADDR <IP> : Setting IP address
          SETSNMASK <SubNet> : Setting subnet mask
          SETGWADDR <GW> : Setting gateway IP address
          R
```

Type "IPCONFIG" To show all IP configurations. To reset the IP, type "RSTIP" and to use a static IP, type "SETIP" (For a full list of commands, see Section 6.4).

Note: Commands will not be executed unless followed by a carriage return. Commands are not case-sensitive. If the IP is changed then the IP Address required for Telnet access will also change accordingly.

6.8 WebGUI Control

On a PC/Laptop that is connected to the same active network as the Matrix, open a web browser and type the unit's IP address on the web address entry bar. The browser will display the unit's Status, Control and User Setting pages.

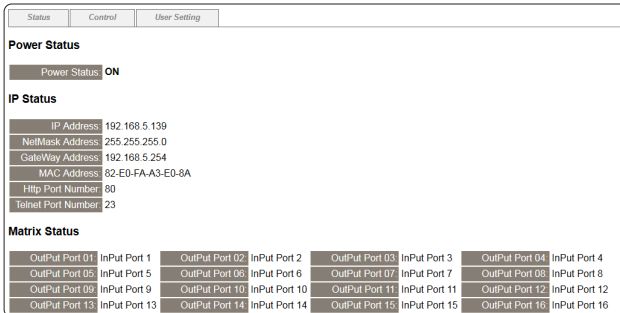

The screenshot shows the 'Status' tab of the WebGUI. It contains the following information:

- Power Status:** Power Status is ON.
- IP Status:**
 - IP Address: 192.168.5.139
 - NetMask Address: 255.255.255.0
 - GateWay Address: 192.168.5.254
 - MAC Address: 82-E0-FA-A3-E0-8A
 - Http Port Number: 80
 - Telnet Port Number: 23
- Matrix Status:** A table showing 16 ports, each with an OutPut Port and an InPut Port label.

Click on the 'Control' tab to control power, input/output ports and reset mode.

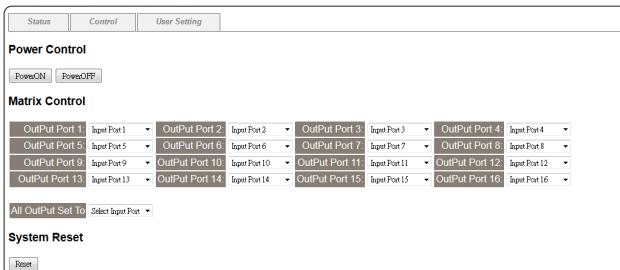

The screenshot shows the 'Control' tab of the WebGUI. It contains the following controls:

- Power Control:** Buttons for PowerON and PowerOFF.
- Matrix Control:** A grid of 16 dropdown menus, each representing a port (OutPut Port and InPut Port).
- All OutPut Set:** A dropdown menu set to 10.
- System Reset:** A Reset button.

Click on the 'User Setting' tab allows you to reset the IP configuration. The system will ask for a reboot of the unit each time any of the settings are changed. The IP address needed to access the WebGUI control will also need to be changed accordingly on the web address entry bar.



The screenshot shows the 'User Setting' tab of the WebGUI. It contains the following settings:

- IP Address Selection:**
 - Address Type: Static IP
 - Static IP Address: 192.168.5.139
 - Subnet Mask: 255.255.255.0
 - Default Gateway: 192.168.5.254
- Update Settings:** A button to save the changes.

7. CONNECTION DIAGRAM

7.1 Example Installation (16x16 HDMI Matrix)

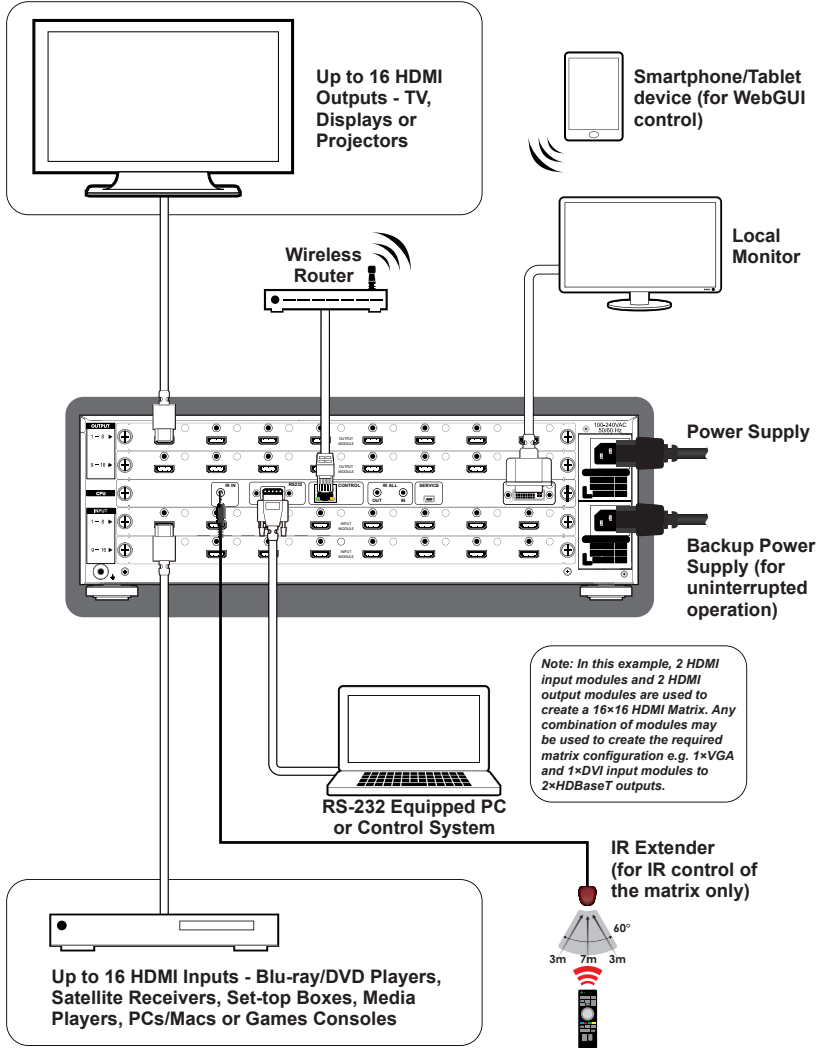

7.2 Input and Output Modules

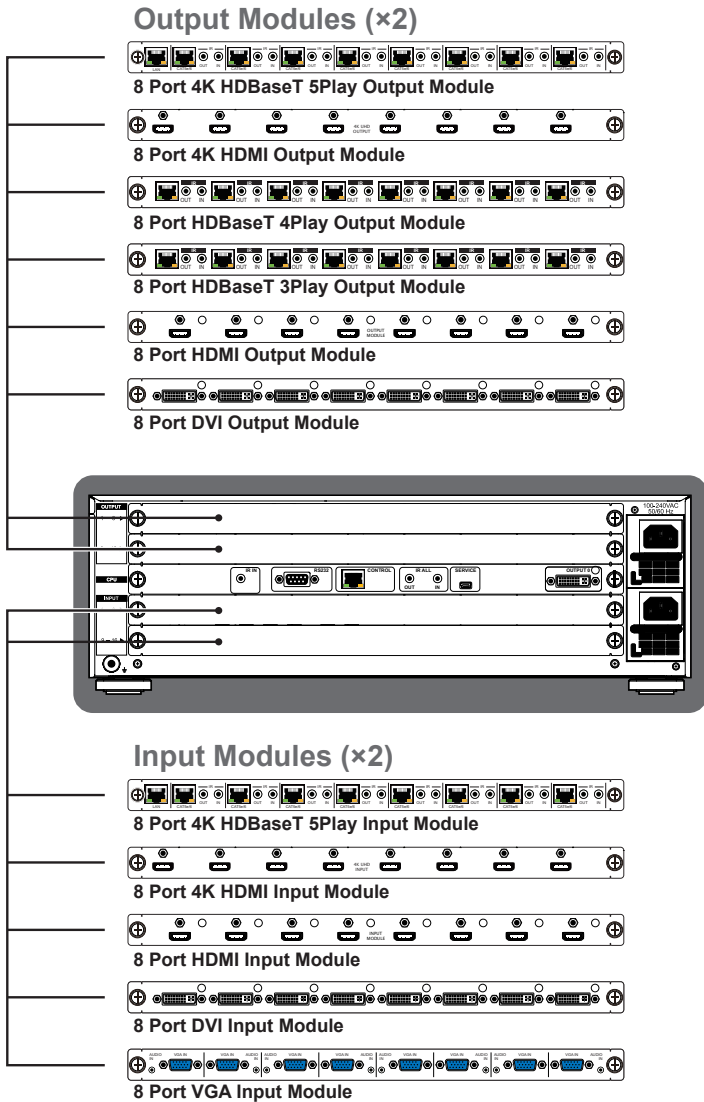

8. SPECIFICATIONS

8.1 Technical Specifications (Enclosure)

Input Ports	Up to 16×HDMI or DVI or CAT5e/6/7 or VGA (dependent on module configuration)
Output Ports	Up to 16×HDMI or DVI or CAT5e/6/7 (dependent on module on module configuration)
Power Supply	2×AC 110~240V (US/EU standards, CE/FCC/ UL certified)
Dimensions	482 mm (W)×484 mm (D)×145 mm (H)
Weight	14,400g
Chassis Material	Metal
Color	Black
Operating Temperature	0°C~40°C/32°F~104°F
Storage Temperature	-20°C~60°C/-4°F~140°F
Relative Humidity	20~90% RH (non-condensing)
Power Consumption	50 W

8.2 Technical Specifications (Input Modules)

8 Port 4K HDBaseT 5Play Input Module	
Video Bandwidth	300 MHz/10.2 Gbps
Features	HD Video/Audio, PoC, Ethernet, IR/RS-232
Input Ports	8×CAT5e/6/7, 1×LAN
Ethernet Speed	100 Mbps
Video Resolutions	PC: VGA~WUXGA HDTV: 480i~1080p & 4K2K@30 Hz
IR Frequency	30~50 Hz
Audio Transmission	LPCM7.1CH, Dolby TrueHD, Dolby Digital Plus, DTS-HD Master Audio (32~192 kHz Fs sample rate)
Power Consumption	45W+10W PoC/each port

8 Port 4K HDMI Input Module	
Video Bandwidth	300 MHz/10.2 Gbps
Input Ports	8×HDMI
Video Resolutions	PC: VGA~WUXGA HDTV: 480i~1080p & 4K2K@30 Hz
Audio Transmission	LPCM7.1CH, Dolby TrueHD, Dolby Digital Plus, DTS-HD Master Audio (32~192 kHz Fs sample rate)
Power Consumption	22W

8 Port HDMI Input Module	
Video Bandwidth	225 MHz/6.75 Gbps
Input Ports	8×HDMI
Video Resolutions	PC: VGA~WUXGA@60 (RB) HDTV: 480i~1080p

8 Port HDMI Input Module	
Audio Transmission	LPCM7.1CH, Dolby TrueHD, Dolby Digital Plus, DTS-HD Master Audio (32~192kHz Fs sample rate)
Power Consumption	20W

8 Port DVI Input Module	
Video Bandwidth	225MHz/6.75 Gbps
Input Ports	8×DVI
Video Resolutions	PC: VGA~WUXGA@60 (RB) HDTV: 480i~1080p
Audio Transmission	LPCM7.1CH, Dolby TrueHD, Dolby Digital Plus, DTS-HD Master Audio (32~192kHz Fs sample rate)
Power Consumption	20W

8 Port VGA Input Module	
Input Ports	8×VGA, 8×2.5mm Audio Phone Jack
Video Resolutions	PC: VGA~WUXGA@60 (RB)
Audio Transmission	Stereo 2.5mm phone jack (included 2.5mm to 3.5mm adaptor)
Power Consumption	22W

8.3 Technical Specifications (Output Modules)

8 Port 4K HDBaseT 5Play Output Module	
Video Bandwidth	300MHz/10.2 Gbps
Features	HD Video/Audio, PoC, Ethernet, IR/RS-232
Output Ports	8×CAT5e/6/7, 8×IR Extender, 8×IR Blaster, 1×LAN
Ethernet Speed	100 Mbps

8 Port 4K HDBaseT 5Play Output Module	
Video Resolutions	PC: VGA~WUXGA HDTV: 480i~1080p & 4K2K@30Hz
IR Frequency	30~50 Hz
Audio Transmission	LPCM7.1CH, Dolby TrueHD, Dolby Digital Plus, DTS-HD Master Audio (32~192 kHz Fs sample rate)
Power Consumption	45W+10W PoC/each port

8 Port 4K HDMI Output Module	
Video Bandwidth	300 MHz/10.2 Gbps
Output Ports	8×HDMI
Video Resolutions	PC: VGA~WUXGA HDTV: 480i~1080p, 4K2K@30Hz
Audio Transmission	LPCM7.1CH, Dolby TrueHD, Dolby Digital Plus, DTS-HD Master Audio (32~192 kHz Fs sample rate)
Power Consumption	22W

8 Port HDBaseT 4Play Output Module	
Video Bandwidth	225 MHz/6.75 Gbps
Features	HD Video/Audio, PoC, IR/RS-232
Output Ports	8×CAT5e/6/7, 8×IR Extender, 8×IR Blaster
Ir Frequency	30~50 Hz
Video Resolutions	PC: VGA~WUXGA HDTV: 480i~1080p
Audio Transmission	LPCM7.1CH, Dolby TrueHD, Dolby Digital Plus, DTS-HD Master Audio (32~192 kHz Fs sample rate)
Power Consumption	43W+10W PoC/each port

8 Port HDBaseT 3Play Output Module	
Video Bandwidth	225 MHz/6.75 Gbps
Features	HD Video/Audio, IR/RS-232
Output Ports	8×CAT5e/6/7, 8×IR Extender, 8×IR Blaster
Video Resolutions	PC: VGA~WUXGA HDTV: 480i~1080p
Ir Frequency	30~50 Hz
Audio Transmission	LPCM7.1CH, Dolby TrueHD, Dolby Digital Plus, DTS-HD Master Audio (32~192 kHz Fs sample rate)
Power Consumption	43 W

8 Port HDMI Output Module	
Video Bandwidth	225 MHz/6.75 Gbps
Input Ports	8×HDMI
Video Resolutions	PC: VGA~WUXGA@60 (RB) HDTV: 480i~1080p
Audio Transmission	LPCM7.1CH, Dolby TrueHD, Dolby Digital Plus, DTS-HD Master Audio (32~192 kHz Fs sample rate)
Power Consumption	20 W

8 Port DVI Output Module	
Video Bandwidth	225 MHz/6.75 Gbps
Output Ports	8×DVI
Video Resolutions	PC: VGA~WUXGA@60 (RB) HDTV: 480i~1080p
Audio Transmission	LPCM7.1CH, Dolby TrueHD, Dolby Digital Plus, DTS-HD Master Audio (32~192 kHz Fs sample rate)
Power Consumption	20 W

8.4 CAT5e/6/7 Cable Specifications

HDBaseT 4Play & 5Play Input/Output Module Cable Distance:

Cable Type	Range	Pixel Clock Rate	Video Data Rate	Supported Video Formats
CAT5e/6/7	100 m	≤225 MHz	≤5.3 Gbps (HD Video)	Up to 1080p@60 Hz, 36-bit, 3D (data rates lower than 5.3 Gbps or below 225 MHz TMDS clock).
	70 m	>225 MHz	>5.3 Gbps (Ultra HD Video)	4K2K@30 Hz video formats

HDBaseT 3Play Input Module Cable Distance:

Cable Type	Range	Pixel Clock Rate	Video Data Rate	Supported Video Formats
CAT5e/6/7	60 m	≤225 MHz	≤5.3 Gbps (HD Video)	Up to 1080p@60 Hz, 36-bit, 3D (data rates lower than 5.3 Gbps or below 225 MHz TMDS clock).

9. ACRONYMS

ACRONYM	COMPLETE TERM
CLI	Command Line Interface
DTS	Digital Theater System
DVI	Digital Visual Interface
EDID	Extended Display Identification Data
GUI	Graphical User Interface
HDCP	High-bandwidth Digital Content Protection
HDMI	High-Definition Multimedia Interface
HDTV	High-Definition Television
LCM	Liquid Crystal Module
PoC	Power over Cable
VGA	Video Graphics Array
WUXGA	Widescreen Ultra Extended Graphics Array



CYPRESS TECHNOLOGY CO., LTD.
www.cypress.com.tw
